

GH12265

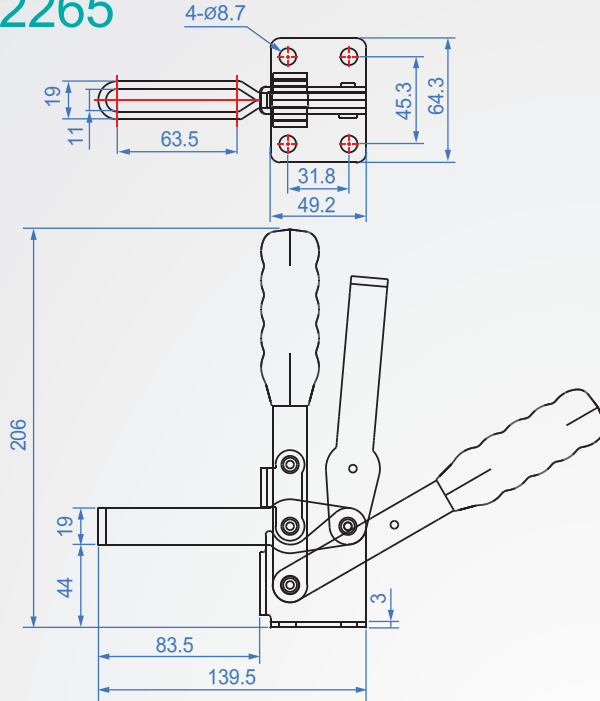

GH12265

材質：SS400 表面處理：鍍鉻

GH12265-SS

材質：SUS304

單位：mm

Code No.	夾壓力(kg)	重量(g)	把手移動	夾頭移動	前端配件
GH12265	340	635	61°	112°	NFC-38312(橡膠)
GH12265-SS	340	635	61°	112°	—

1N=0.102kgf