

Precision Lock Nut

MR779

Radial Lock

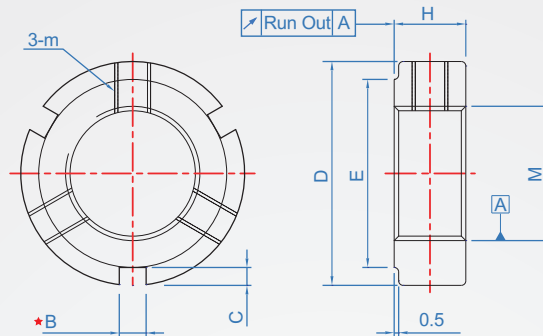

*B
*3 grooves when hook wrench slot is M6 ~ M100;
M105~6 grooves.

Material	Finish	Thread Accuracy	Run Out	Accessory
SUS304	Fat remove	ISO 4H level	0.005mm	Copper in the front Set screw
SCM440 HRC28~32	BK		0.005mm (standard)	
			0.002mm (advanced)	

※The thread direction is the right thread.
If you need the left thread,
please contact us.

How to order

1 2
MR779 - M6 - 0.5 -
TYPE Thread Pitch
Choose Materials & Run Out
standard 0.005
standard 0.005 SUS
advanced 0.002 G

Thread	Pitch	standard (0.005mm)		advanced (0.002mm)		H	B	C	Set Screw	
		D	E	D	E				m	Release torque
M6	0.5	16	11	16	11	8	3-3	2	M4	2.2 (max. Nm)
M8	0.75									
M8	1									
M10	0.75	18	13	18	13	10	3-4	2	M5	4.8 (max. Nm)
M12	1									
M15	1	25	21	28	23	12	3-5	2.5	M6	8 (max. Nm)
M17	1.5									
M20	1.5	32	27	35	30	14	3-6	3	M8	19 (max. Nm)
M25	2									
M30	2	45	40	48	43	16	3-7	4	M10	36 (max. Nm)
M35	3									
M40	3	52	47	53	48	18	3-8	5	M12	45 (max. Nm)
M45	3									
M50	3	70	64	70	64	20	3-10	6	M14	55 (max. Nm)
M55	3									
M60	3	80	73	80	73	22	3-12	7	M16	65 (max. Nm)
M65	3									
M70	3	92	84	92	84	24	3-14	8	M18	75 (max. Nm)
M75	3									
M80	3	105	96	105	96	26	3-16	9	M20	85 (max. Nm)
M85	3									
M90	3	112	104	112	104	28	3-18	10	M22	95 (max. Nm)
M95	3									
M100	3	123	113	123	113	30	3-20	11	M24	105 (max. Nm)
M105	3									
M110	3	137	125	137	125	32	3-22	12	M26	115 (max. Nm)
M115	3									
M120	3	155	142	155	142	34	3-24	13	M28	125 (max. Nm)
M125	3									
M130	3	160	147	160	147	36	3-26	14	M30	135 (max. Nm)
M135	3									
M140	3	165	152	165	152	38	3-28	15	M32	145 (max. Nm)
M145	3									
M150	3	195	180	195	180	40	3-30	16	M34	155 (max. Nm)
M155	3									
M160	3	210	190	210	190	42	3-32	17	M36	165 (max. Nm)
M165	3									
M170	3	220	200	220	200	44	3-34	18	M38	175 (max. Nm)
M180	3									
M185	3	230	210	230	210	46	3-36	19	M40	185 (max. Nm)
M190	3									
M195	3	240	220	240	220	48	3-38	20	M42	195 (max. Nm)
M200	3									