

Spring washer

WS782

DIN127B

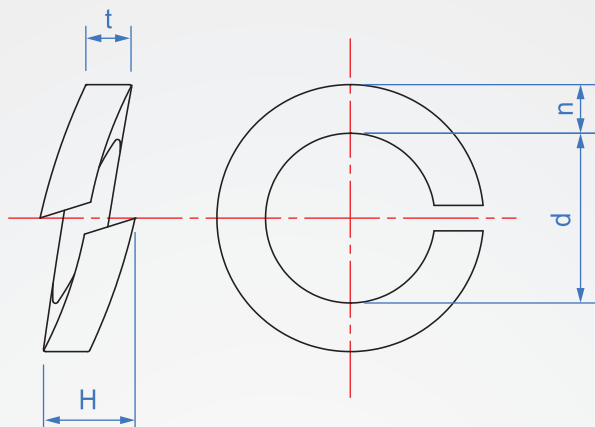

Material

Steel (Galvanization)

SUS304

How to order

WS782 - M2 -

 TYPE M

Select material

Steel.....

 SUS304..... SUS



Unit : mm

Applicable screws	t	Tolerance	n	Tolerance	d		H		
					max.	min.	max.	min.	
M2	0.5	+0.1 ~ -0.1	0.9	+0.1 ~ -0.1	2.4	2.1	1.2	1	
M2.5	0.6		1		2.9	2.6	1.4	1.2	
M3	0.8		1.3		3.4	3.1	1.9	1.6	
M4	0.9		1.5		4.4	4.1	2.1	1.8	
M5	1.2		1.8		5.4	5.1	2.8	2.4	
M6	1.6	+0.15 ~ -0.15	2.5	+0.15 ~ -0.15	6.5	6.1	3.8	3.2	
M8	2		3		8.5	8.1	4.7	4	
M10	2.2		3.5		10.7	10.2	5.2	4.4	
M12	2.5		4		12.7	12.2	5.9	5	
M16	3.5		5		17	16.2	8.3	7	
M20	4	+0.2 ~ -0.2	6	+0.2 ~ -0.2	21.2	20.2	9.4	8	
M24	5		7		25.5	34.5	11.8	10	
M30	6		8		+0.15 ~ -0.15	31.7	30.5	14.2	12

Che Na

886-2688-3177

info@chena.com.tw

 886-22688-3188
886-2688-3881~3

 No.21, Guangrong St. Shulin Dist.,
New Taipei City 238 Taiwan (R.O.C.)