

Square steel sheet

GF412 Clamping

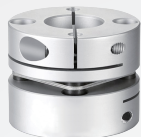

How to order

GF412 - 19 - 3-3

TYPE D d1xd2

Select the body material
 AL-High strength aluminum alloy... Blank
 SUS..... SUS

| Ontology | Disc.Pin | Hexagon socket head cap screws |
|--|-----------------|--------------------------------|
| High strength aluminum alloy (White anode) | stainless steel | SCM435 (Dye black) |
| SUS | | SUS |

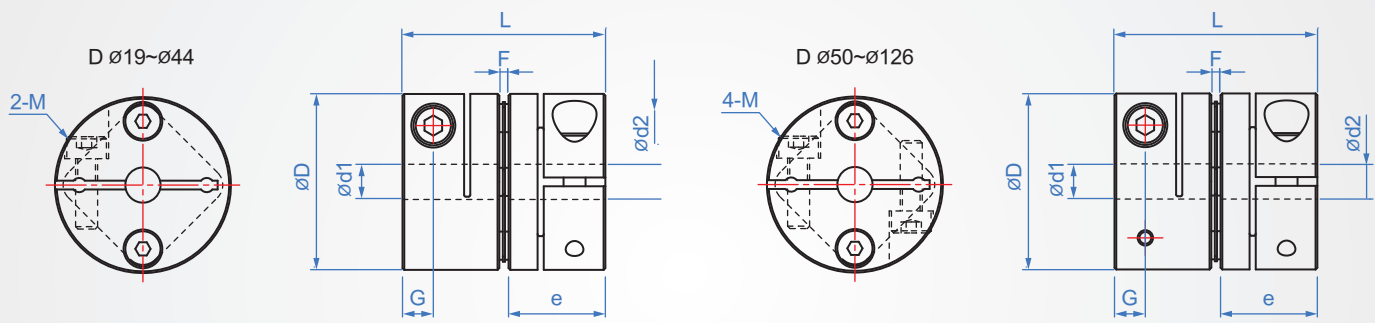

| D | Inner hole designation d1-d2 | | L | e | F | M | G | Max. torque (N · m) | | Allowable axial displacement (mm) | | Max. revolutions (rpm/min) | Static torsion spring coefficient (N·m/rad) | | Moment of inertia (kg · m ²) | | weight g | | | | | | | | |
|-----|------------------------------|------|------|-------|-----|------|------|---------------------|-------|-----------------------------------|--------|----------------------------|---|----------------------|--|-----------------------|----------|------|-----|-------|-------|-----------------------|----------------------|----------------------|----------------------|
| | min. | max. | | | | | | AL | SUS | AL | SUS | | AL | SUS | AL | SUS | AL | SUS | | | | | | | |
| | unit : mm | | | | | | | | | | | | | | | | | | | | | | | | |
| 19 | 3 | ~ 8 | 20 | 9.1 | 1.8 | M2.5 | 3.3 | 1 | 1.8 | ±0.09 | ±0.09 | 10000 | 1400 | 1582 | 6.7x10 ⁻⁷ | 7.4x10 ⁻⁷ | 11 | 40 | | | | | | | |
| 26 | 3 | ~ 14 | 26 | 11.65 | 2.6 | M3 | 3.9 | 1.5 | 2.2 | ±0.14 | ±0.14 | | 3700 | 4100 | 2.2x10 ⁻⁶ | 3.3x10 ⁻⁶ | 28 | 70 | | | | | | | |
| 32 | 5 | ~ 15 | 28 | 12.25 | 3.5 | | 3.85 | 2 | 3 | ±0.18 | ±0.18 | | 5700 | 5760 | 7.1x10 ⁻⁶ | 8.1x10 ⁻⁶ | 46 | 106 | | | | | | | |
| 34 | 5 | ~ 16 | 32 | 14.25 | | 4.85 | 3 | 4.5 | 8100 | | | | 9070 | 8x10 ⁻⁶ | 1.2x10 ⁻⁶ | 55 | 137 | | | | | | | | |
| 39 | 8 | ~ 19 | 34.5 | 14.9 | 4.5 | M4 | 5 | 6 | 9 | ±0.23 | ±0.23 | | 18000 | 20000 | 2.2x10 ⁻⁵ | 3.3x10 ⁻⁵ | 81 | 202 | | | | | | | |
| 44 | 8 | ~ 24 | | | | | | 9 | 13 | ±0.27 | ±0.27 | 20000 | 22400 | 2.8x10 ⁻⁵ | 4.2x10 ⁻⁵ | 99 | 247 | | | | | | | | |
| 56 | 10 | ~ 32 | 45 | 19.75 | 5.5 | M5 | 6.4 | 25 | 37 | ±0.36 | ±0.36 | 9000 | 50000 | 56000 | 1.2x10 ⁻⁴ | 1.8x10 ⁻⁴ | 217 | 542 | | | | | | | |
| 68 | 12 | ~ 38 | 53 | 23.35 | 6.3 | M6 | 7.7 | 60 | 90 | ±0.40 | ±0.40 | | 70000 | 78000 | 1.5x10 ⁻⁴ | 2.25x10 ⁻⁴ | 348 | 870 | | | | | | | |
| 82 | 17 | ~ 42 | | | | | | | | | | | 68 | 30 | 8 | M8 | 9.7 | 80 | 150 | ±0.50 | ±0.50 | 140000 | 168000 | 1.8x10 ⁻⁴ | 2.7x10 ⁻⁴ |
| 94 | 19 | ~ 45 | 10 | M10 | 10 | 165 | 245 | ±0.70 | ±0.70 | 100000 | 110000 | | | | | | | | | | | 1.23x10 ⁻³ | 2.3x10 ⁻³ | 960 | 1850 |
| 104 | 20 | ~ 48 | | | | 235 | 340 | ±0.80 | ±0.40 | 120000 | 130000 | | | | | | | | | | | 1.85x10 ⁻³ | 2.5x10 ⁻³ | 1200 | 2450 |
| 126 | 20 | ~ 55 | 78 | 33 | 12 | M12 | 12 | 350 | 450 | ±0.90 | ±0.45 | 7500 | 135000 | 151200 | 3.75x10 ⁻³ | 4.5x10 ⁻³ | 1500 | 3050 | | | | | | | |

Allowable declination : 1°

Copyright © CHENA INDUSTRIAL CO., LTD ALL Rights Reserved.

Che Na

FAX 886-2688-3177

info@chena.com.tw

886-22688-3188
886-2688-3881~3

No.21, Guangrong St. Shulin Dist.,
New Taipei City 238 Taiwan (R.O.C.)