

鑄鐵

OA964

盤形

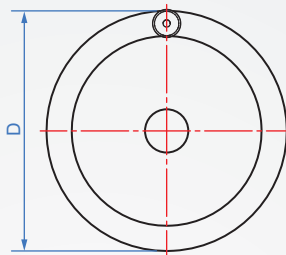
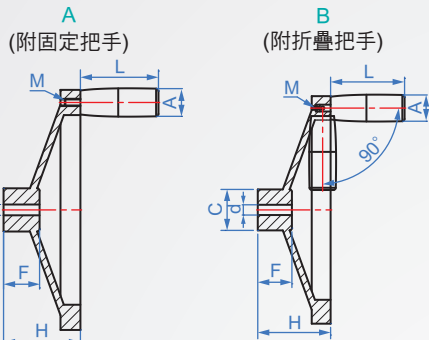
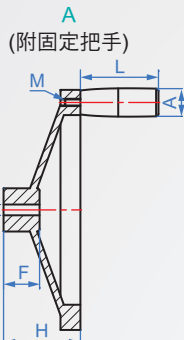

類型	本體		把手	
	材質	表面處理	材質	表面處理
A	鑄鐵	電鍍鉻	鐵	電鍍鉻
B		噴砂		

How to order

OA964 - A - 125 - N10 -

TYPE No. D 指定孔

選擇表面處理

電鍍鉻..... CR

噴砂..... SN

P 圓孔+攻牙120°

N 鍵槽+攻牙120°

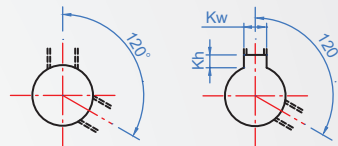

■軸孔 P、N 尺寸表 (新JIS B 1301)

No.	D	d	孔形	孔徑	C	F	H	旋轉把手			質量 kg	
								A	L	M		
A (附固定把手)	125	7	P	8~17	36	21	46	19	70	5/16"	1.2	
	150	8		10~20	43	26	51	23	90	3/8"	1.7	
	175	8		10~22	47	30	58				2.4	
	200	9		10~22	49	31	64	2.9				
	250	9		10~30	57	31	67	4.5				
B (附折疊把手)	125	7		N	8~17	36	20	46	23	65	M6	1.2
	150	8			10~20	44	25	51	26	80		1.7
	175	8			10~22	48	30	58	28	90	2.4	
	200	9			10~22	49	30	64			2.9	
	250	9			10~30	57	33	68	4.5			

單位: mm

軸孔徑	Kw	Kh	攻牙
8~10	3	1.4	M4
11~12	4	1.8	
13~17	5	2.3	M5
18~22	6	2.8	M6
23~30	8	3.3	