

軸徑 12~63  
T 系列  
筒形鍵槽式

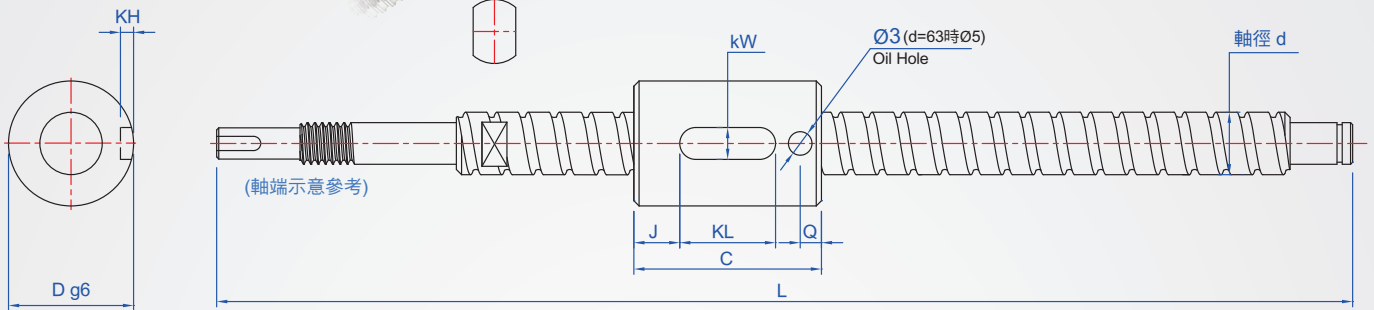

精度	螺桿	軸部硬度		螺帽	
		材質	硬度	材質	硬度
C7	轉造級	S55C	高週波淬火 (HRC60)	SCM415H	滲碳淬火 (HRC60)
C5	研磨級				

■ 導程精度 (JIS B 1192) 單位: mm

精度等級	C7	C10
累積導程誤差	±0.05/300	±0.21/300

任意取有效螺紋300mm的基準導程對  
累積導程誤差(±Ec)與變動(e)的容許值

■ 軸向標準間隙 單位: mm

軸徑	軸向間隙(max)
12	0.05
14~28	0.10
30~32	0.14
36~45	0.17
50~63	0.20

■ 內循環特點構造

螺帽外徑較為輕巧，適合內部空間較小的機器

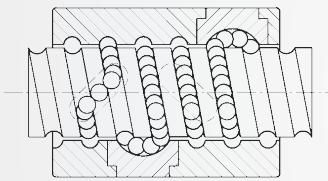

### How to order

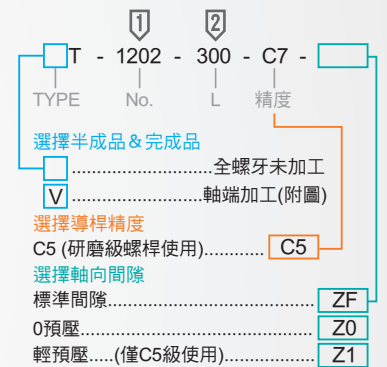

單位: mm

No.	d 軸徑	導程	L 指定 1mm	C	D	J	鍵槽尺寸			球徑	Q	基本額定負荷	
							KW	KH	KL			Ca(動)kN	Ca(靜)kN
1202	12	2	100 ~ 800	30	24	9	3	1.5	12	1.2	4	265	377
1204		4		11.5		2.381				645		693	
1205		5		14		2				514		594	
1210		10				390				466			
1602	16	2	120 ~ 1200	40	28	10	5	2	20	1.2	5	300	503
1604		4		12.5		2.381				944		1254	
1605-A		5		15						1049		1144	
1605-B		5		15						1344		1525	
1610	10			45		12.5			3.175		7	1181	1496
1616	16			45		12.5			3.175		7	833	997
2005-A	20	5	200 ~ 1500	47	36	13.5	5	2	20	3.175	7	1181	1496
2005-B		5		16.5						1512		1995	
2006		6		17						1568		1787	
2010		10		17.5						1765		2338	
2020	20			55		17.5			3.175		7	1659	2464
2505	25	5	250 ~ 1500	53	40	16.5	5	2	20	3.5	7	1704	2581
2510		10		17						1614		2460	
3205	32	5	300 ~ 2000	53	50	11.5	6	2.5	30	3.175	7	1924	3403
3210		10		20						3775		5877	
3220		20		24						2141		3576	
4005		5		13						2142		4342	
4010	40	10	400 ~ 2000	80	63	25	6	2.5	30	6.35	7	4216	7556
4020		20		16.5						3782		6468	
5010	50			82	75	23			5.556		7	4633	9235
6310	63	10	500 ~ 3000	90	85	29			3.5		14	6700	16230