

## GH304-EM

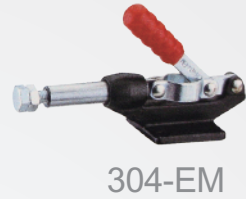
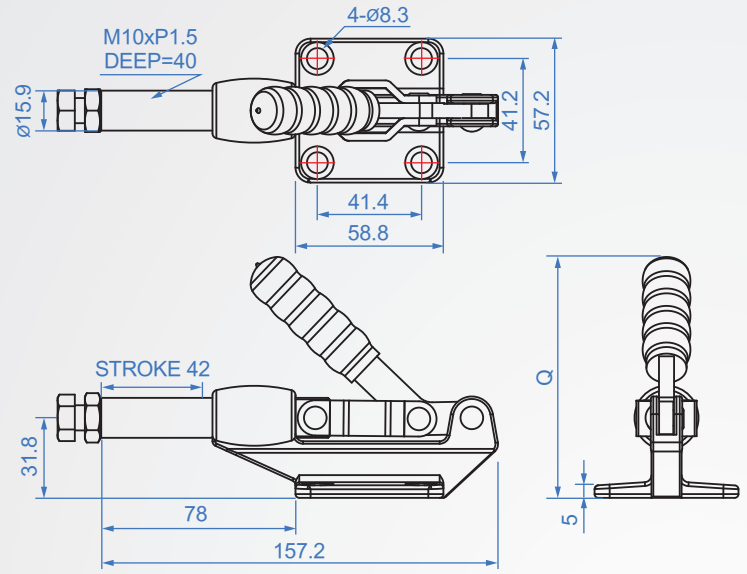

### GH304-EM

材質：SS400 表面處理：鍍鋅

單位：mm

Code No.	夾壓力(kg)	重量(g)	Q	把手移動	行程	前端配件
GH304-EM	386	591	95.7	183°	42	NSA-105015
GH305-EM	386	591	124.9	183°	42	NSA-105015

1N=0.102kgf

版權所有 重製必究